

GRADALL®

XL 4100_{II}

HYDRAULIC EXCAVATOR

SPECIFICATIONS



XL 4100_{II}

Undercarriage

6 x 4 or 6 x 6
Wheelbase: 171" (4.34m)
Width 102" (2.6m)

Frame:

48" (1.2m) wide, welded plate design
50 ksi material

Gross vehicle axle weight rating:

6 x 4 60,600 lb (27,488 kg)
6 x 6 65,000 lb (29,484 kg)

Front axles:

6 x 4: Meritor Model FG-941, 14,600 lb (6,623 kg) rating
6 x 6: Meritor Model MX19-145, 19,000 lb (8,618 kg) rating, 7.17 ratio

Rear axle:

Meritor Model RT-46-160, 46,000 lb (20,866 kg) rating, 7.17 ratio, single reduction with driver controlled differential lock in front/rear and interaxle differential with lock.

Suspension:

Front: 8 leaf spring with automatic lock-out cylinders
Rear: Hendrickson Equalizer Beam, 8" oscillation

Brakes:

6 x 4 Front: Meritor "Q" Series Cam-Master Size: 16.5" x 5" (419 mm x 152 mm)
Automatic Slack Adjusters

6 x 6 Front: Meritor "Q" Series Cam-Master Size: 16.5" x 6" (419 mm x 127 mm)
Automatic Slack Adjusters

Rear: Meritor "P" Series Cam-Master Size: 16.5" x 7" (419 mm x 178 mm)
Automatic Slack Adjusters

Spring brake system incorporates emergency and parking brakes on the rear axle. Heated air dryer.

Wheels:

Hub piloted disc 10-stud, 11.25" (286 mm) bolt circle.

Tires:

6 x 4 and 6 x 6 front: 385/65R22.5 18-ply on/off highway tread
6 x 4 and 6 x 6 rear: 11R22.5 16-ply traction tread

Steering:

Ross, integral hydraulic power steering.
Gear type power steering pump. 4-quart power steering reservoir with filter.

Standard chassis equipment:

Halogen headlights, tail lights, back-up lights and alarm, stoplights, identification lights front and rear, directional lights, 4-way hazard lights, and instrument panel lights.
Windshield wiper/washer, West Coast style mirror system with plane and convex mirrors, front and rear tow hooks, desiccant type air dryer with automatic purge valve and thermostatically controlled heater.

Hydraulic System

PUMPS

One load-sensing axial piston pump; 0-77 GPM (0-291 L/min) total.

SYSTEM SPECIFICATIONS

Four double acting cylinders

- 2 boom hoist: 4.25" ID, 3.15" rod (108mm x 80mm), 31" (787mm) stroke
- 1 tool: 5.00" ID, 3.0" rod (127mm x 76mm), 22.5" (572mm) stroke
- 1 telescope: 3.5" ID, 2.559" rod (89mm x 65mm), 12.6" (3.81 m) stroke

Four hydraulic motors

Swing, 68 Hp (51kW); tilt, 21 Hp (16kW); two remote drive, 65 Hp (48kW) total.

Operating pressures

Hoist	4,700 psi (32,405 kPa)
Tilt	2,400 psi (16,547 kPa)
Swing	4,200 psi (28,958 kPa)
Tool	4,700 psi (32,405 kPa)
Telescope	4,700 psi (32,405 kPa)
Remote Propel	...	3,500 psi (24,130 kPa)
Pilot system500 psi (3,448 kPa)

Oil capacity

Reservoir 50 gallons (189 L), system 68 gallons (257 L). Pressurized reservoir with visual oil level gauges.

Filtration system

10 micron return filter with magnet.

Fin and tube-type oil cooler with thermostatically controlled cooling fan.

Pressure-compensated, load-sensing valves with circuit reliefs in all circuits.

Chassis Cab

One-person cab, left-hand mount, isolated from frame on rubber mounts. Acoustical lining. Sun visor. Gauges for oil pressure, coolant temperature, air tank pressures, fuel level, voltmeter, speedometer with odometer, tachometer with hour meter. Engine monitor lights. Engine shutdown controlled by engine electronics. Indicator lights and controls for front axle engagement (6 x 6 only) and rear axle differential lock. Park brake control. Tinted safety glass. Sliding side windows. Fresh air heater and defroster. Dome light. Air suspension seat with seat belt.

Upperstructure Cab

All-weather cab isolated from frame on rubber mounts. Tinted safety glass windows, skylight, acoustical lining, four-way adjustable operator's seat, dome light, filtered air heater and defroster.

The heat source is provided by a fast response, closed circuit hydraulic heater with 20,000 BTU/Hr. capacity.

Front window slides to overhead storage. Rearview mirrors on right and left sides of the machine. Windshield wiper and washer.

Hydraulic Remote Control

Undercarriage powered by upperstructure hydraulics through hydraulic motors and PTOs on transmission. Travel and steering pedals in upperstructure cab. Digging brakes and front axle lockout cylinders set automatically with travel pedal in neutral. Parking brakes controlled by toggle.

Electrically operated alarms mounted on undercarriage signal remote control movement in either direction, reverse movement when driven from undercarriage cab.

Engine

Detroit Diesel OM906 diesel with EGR. 4 cycle, inline 6 cylinder, liquid cooled. Turbo/Charge air aftercooled. Automotive Certified, 2004 EPA/CARB Regulations. Electronic controlled. Vertical canister style lube filter and centrifugal lube filter attached to engine. Vertical canister style fuel filters, (main and pre-filter) attached to engine. Remote mount primary fuel/water separator. Gross Rating: 250HP @ 2300 RPM. 660 ft.lb. Torque @ 1200 RPM. Net Rating: 233 HP @ 2300 RPM.

Air Filter: 2-stage dry type with safety element, ejector valve and service indicator.

Electrical System: 12 volt, 100 amp alternator with integral voltage regulator. 2 SAE #C31-S 810 CCA batteries.

Cooling System: Fin and tube radiator with fan shroud. 8 blade, 28" diameter fan. Engine charge air cooler mounted in front of radiator. Transmission oil cooler mounted in front of radiator below charge air cooler.

Fuel Tank Capacity: 100 gal (378 L)

Transmission: Eaton Roadranger RTX-14609B, 9-speed FWD, 2-speed reverse. Internal oil pump with external spin-on filter. Transmission oil cooler. Neutral start switch. Input shaft clutch brake. 8-bolt air shifted PTO for hydraulic pump drive. Dual rear countershaft, air shifted PTO's for remote propel motors.

Gear Speeds: (with 11R22.5 tires)

Gear	Lo	1	2	3	4	5	6	7	8
MPH	3.1	5.2	7.4	10.2	14.0	20.0	28.3	39.0	53.4
Km/hr	(4.9)	(8.4)	(11.9)	(16.4)	(22.5)	(32.2)	(45.3)	(62.7)	(85.9)

Gear	Rev Lo	Rev Hi
MPH	3.4	13.1
Km/hr	(5.5)	(21.1)

Clutch: Hydraulic actuated. Spicer Model 107, pull type. 14" dia, 2-plate, organic disc.

Drivelines: Spicer 1760 Series with "Half Round" yokes.

Transfer Case: (6 x 6 only) Meritor Model T-211HD, 1/1 ratio, 3 shaft single speed. With air operated front axle disconnect.

Upperstructure Controls

Two hydraulic joysticks (hoist & bucket, telescope & swing), one rocker switch (tilt) control upperstructure. Hydraulic joysticks are mounted on arm pods that are adjustable for individual operator comfort and convenience. Quick change joystick pattern with decals is standard.

Two foot pedals for remote control of undercarriage steering, travel and digging brakes. Rocker switch on control panel selects low speed or high speed remote travel.

Joysticks and pedals are self-centering; when controls are released, power for movement disengages and swing and travel brakes set automatically.

Engine Controls

Key ignition switch with neutral start and indicator lights for low air, engine status, park brake, travel status, hydraulic filter condition and hydraulic fluid temperature and level.

Automatic engine shut down occurs with low oil pressure or high coolant temperature.

Swing

Internal swing gear. Priority swing circuit with axial piston motor. Planetary transmission. Swing speed: 8 rpm.

Swing brake: Automatic spring-set/hydraulic release wet disc parking brake. Dynamic braking is provided by the hydraulic system.

GRADALL Model XL 4100_{II} Lift Capacity Over Side or Rear - LB. (KG.)

LOAD POINT HEIGHT		LOAD RADIUS										
		10' (3.0m)		15' (4.6m)		20' (6.1m)		25' (7.6m)		Maximum Radius	Over End	Over Side
		Over End	Over Side	Over End	Over Side	Over End	Over Side	Over End	Over Side			
Above Ground Level	20' (6.1m)									23'2" (7.1m)	4760 (2160)	4760 (2160)
	15' (4.6m)			9720 (4410)	9720 (4410)	6760 (3065)	6760 (3065)	4915 (2230)	4915 (2230)	25'7" (7.8m)	4745 (2150)	4745 (2150)
	10' (3m)			11465 (5200)	*11270 (5110)	7605 (3450)	*7200 (3265)	5395 (2445)	*5000 (2270)	26'9" (8.2m)	4820 (2185)	*4445 (2015)
	5' (1.5m)			11880 (5390)	*10890 (4940)	7895 (3580)	*7010 (3180)	5595 (2540)	*4890 (2220)	26'11" (8.2m)	4945 (2245)	*4295 (1950)
At Ground Level				10530 (4775)	*10480 (4755)	7475 (3390)	*6795 (3080)	5455 (2475)	*4760 (2160)	26'2" (8.0m)	5095 (2310)	4420 (2005)
Below Ground Level	5' (1.5m)	9465 (4295)	9465 (4295)	8410 (3815)	8410 (3815)	6560 (2975)	6560 (2975)			24'2" (7.4m)	5245 (2380)	*4900 (2225)
	10' (3m)	6205 (2815)	6205 (2815)	6430 (2915)	6430 (2915)	5475 (2485)	5475 (2485)			20'9" (6.3m)	5315 (2410)	5315 (2410)
	15' (4.6m)	4100 (1860)	4100 (1860)							14'8" (4.5m)	4840 (2195)	4840 (2195)

NOTE: The loads shown are in compliance with SAE standard J1097 NOV 88. They do not exceed 87% of the hydraulic lifting capacity or 75% of the tipping capacity.

*Loads shown indicate the load is limited by tipping rather than hydraulic lift capacity.

The rated lift capacity is based on the machine being equipped with 7,500 lb (3400 kg) counterweight, standard boom and no bucket. Adjust the listed rated capacities according to each bucket as follows:

8065-6007	60"	(1.5m) Ditching	- 820lbs. (370kg)
8065-6006	66"	(1.7m) Ditching	- 905lbs. (410kg)
8065-6002	72"	(1.8m) Ditching	- 975lbs. (440kg)
8045-6020	24"	(610mm) Excavating	- 560lbs. (255kg)
8045-6021	30"	(762mm) Excavating	- 665lbs. (300kg)
8045-6022	36"	(914mm) Excavating	- 750lbs. (340kg)
8045-6023	42"	(1.1m) Excavating	- 840lbs. (380kg)
8045-6024	48"	(1.2m) Excavating	- 960lbs. (435kg)
8065-6013	72"	(1.8m) Dredging	- 1100lbs. (500kg)
8065-6102	40"	(1.0m) Pavement	- 1285lbs (580kg)
8065-6024	8'	(2.4m) Blade	- 630lbs. (285kg)
8065-6009	24"	Single Tooth Ripper	- 620lbs. (280kg)

NOTE: Bucket adjustment values are 87% of the actual bucket weights.

The load point is located on the bucket pivot point, including load listed for maximum radius.

Do not attempt to lift or hold any load greater than these rated values at specified load radii and heights. The weight of slings and any auxiliary devices must be deducted from the rated load to determine the net load that may be lifted.

ATTENTION: All rated loads are based on the machine being stationary and level on a firm supporting surface. For safe working loads, the user must make allowance for his particular job conditions such as soft or uneven ground, out of level conditions, side loads, hazardous conditions, experience of personnel, etc. The operator and other personnel must be fully trained and understand the Operator's Manual and Safety Manuals furnished by the manufacturer before operating this machine. Rules for safe operation of equipment must be adhered to at all times.

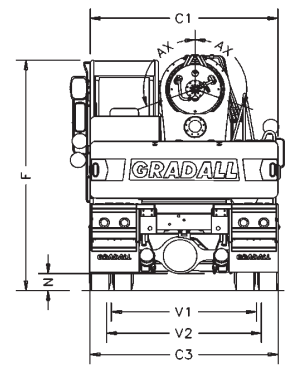
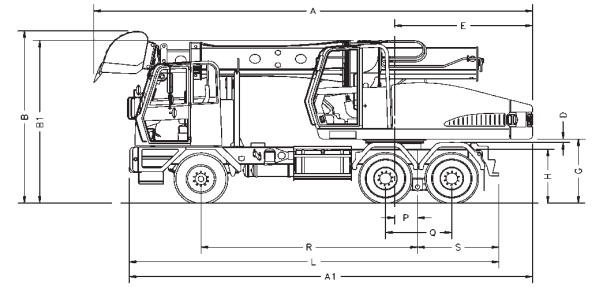
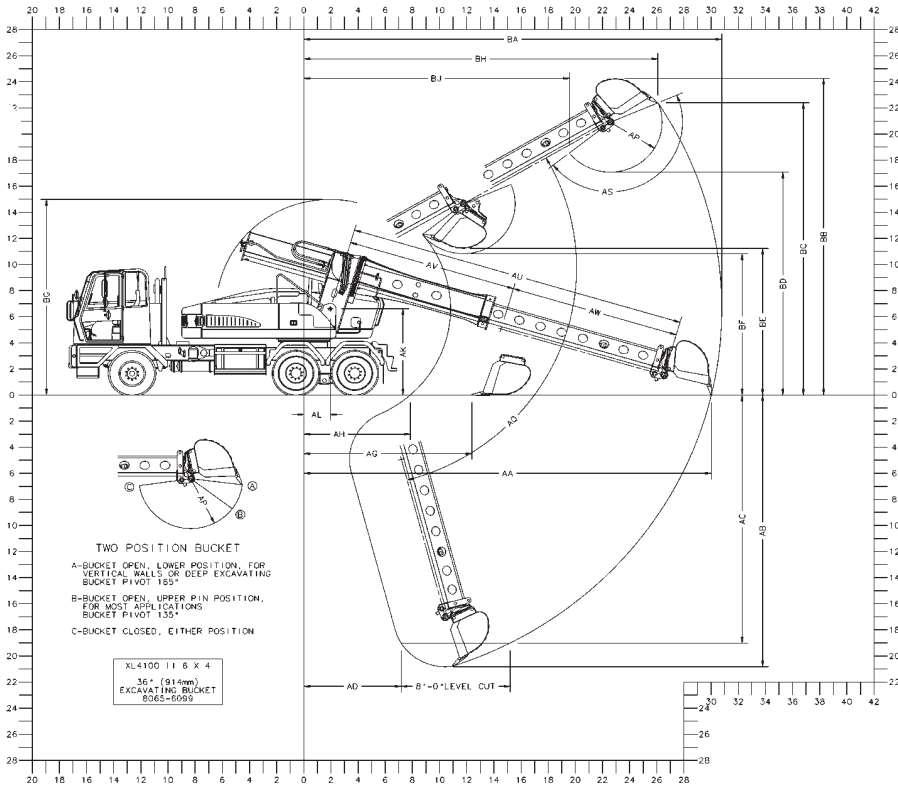

Shown with 8065-6099 36" (914mm) excavating bucket

6x6	6x4	
A 28' 8" (8.7m)	28' 8" (8.7m)	Overall length (boom in rack) with bucket
A1 26' 5" (8m)	26' 5" (8m)	Overall length (boom in rack) without bucket
B 12' 0" (3.6m)	11' 8" (3.5m)	Overall height (boom in rack) with bucket
B1 11' 4" (3.4m)	11' 1" (3.4m)	Overall height (boom in rack) without bucket
C1 8' 6" (2.6m)	8' 6" (2.6m)	Width of upperstructure
C3 8' 6" (2.6m)	8' 6" (2.6m)	Width of undercarriage
D 3" (76mm)	3" (76mm)	Minimum clearance, upperstructure to undercarriage
E 9' 0" (2.7m)	9' 0" (2.7m)	Swing clearance, rear of upperstructure
F 11' 1" (3.4m)	10' 10" (3.3m)	Top of cab to ground line
G 56" (1.4m)	52" (1.3m)	Clearance, upperstructure to groundline
H 47" (1.2m)	44" (1.1m)	Top of wheel mounted under carriage frame to groundline
L 24' 2" (7.4m)	24' 2" (7.4m)	Overall length of undercarriage
N 10" (254mm)	10" (254mm)	Ground clearance (per SAE J1234)
P 18" (457mm)	18" (457mm)	Center of rear tandem to axis of rotation
Q 52" (1.3m)	52" (1.3m)	Distance between centers of tandem axles
R 14' 3" (4.3m)	14' 3" (4.3m)	Wheelbase
S 5' 4" (1.6m)	5' 4" (1.6m)	Center of tandem axles to rear of frame(step)
V1 6' 7" (2.0m)	6' 7" (2.0m)	Tread, rear axles (10:00 x 20 tires)
V2 7' 0" (2.1m)	7' 0" (2.1m)	Tread, front axle (15:00 x 22.50 tires)
AA 29' 11" (9.1m)	30' 1" (9.2m)	Maximum radius at groundline (165° pivot)
AB 20' 6" (6.2m)	20' 10" (6.3m)	Maximum digging depth (165° pivot)
AC 18' 9" (5.7m)	19' 0" (5.8m)	Maximum depth for 8' level cut
AD 7' 2" (2.2m)	7' 2" (2.2m)	Minimum radius of 8' level cut at depth "AC"
AG 12' 4" (3.7m)	12' 4" (3.7m)	Minimum level cut radius with bucket flat on groundline
AH 7' 6" (2.3m)	7' 10" (2.4m)	Minimum radius at groundline
AK 6' 11" (2.1m)	6' 7" (2m)	Boom pivot to groundline
AL 23" (584mm)	23" (584mm)	Boom pivot to axis of rotation
AP 46" (1.2m)	46" (1.2m)	Bucket tooth radius
AQ 30° Up & 75° Down	30° Up & 75° Down	Boom pivot angle
AS 135° & 165°	135° & 165°	Bucket pivot angle
AU 25' 0" (7.6m)	25' 0" (7.6m)	Maximum telescoping boom length (boom pivot to bucket pivot)

6x6	6x4	
AV 12' 6" (3.8m)	12' 6" (3.8m)	Minimum telescoping boom length (boom pivot to bucket pivot)
AW 12' 6" (3.8m)	12' 6" (3.8m)	Telescoping boom travel
AX 110°	110°	Boom tilt angle (both sides of center)
BA 30' 9" (9.4m)	30' 9" (9.4m)	Maximum radius of working equipment (165° pivot)
BB 24' 7" (7.5m)	24' 3" (7.4m)	Maximum height of working equipment
BC 22' 8" (6.9m)	22' 5" (6.8m)	Maximum bucket tooth height
BD 17' 4" (5.3m)	17' 1" (5.2m)	Minimum clearance of bucket teeth, with bucket pivot at maximum height
BE 11' 6" (3.5m)	11' 3" (3.4m)	Minimum clearance of fully curled bucket at maximum boom height (165° pivot)
BF 11' 1" (3.4m)	10' 10" (3.3m)	Minimum clearance of bucket teeth at maximum boom height
BG 15' 3" (4.6m)	15' 0" (4.6m)	Maximum height of working equipment with bucket below groundline
BH 26' 1" (7.9m)	26' 1" (7.9m)	Radius of bucket teeth at maximum height (165° pivot)
BJ 19' 7" (5.9m)	19' 7" (5.9m)	Minimum radius of bucket teeth at maximum bucket pivot height (165° pivot)

Rated bucket tangential force with 36" (914mm) bucket: 24,411 lb. (108kN)
 Rated telescoping boom crowd force: 21,045 lb. (93.6kN)

WEIGHT

Approximate working weight, including 36" (914mm) bucket, fuel tank half full -
 6 x 4: 46,940 lb. (21,292kg)
 6 x 6: 48,860 lb. (22,163kg)

Specifications subject to change without notice.

Optional Equipment

Work lights: 2 spotlights on boom cradle, 3 floodlights on cab, 1 floodlight on right front shrouding.

Vandalism protection kit including window covers.

Intake air pre-cleaner.

Exhaust spark arrestor.

Strobe light.

Block heater.

Additional battery.

Air conditioning, either cab.

Tilt steering column.

AM/FM radio installation, either cab.

Auxiliary Hydraulics - Inside hose trough with additional hosing and piping for hydraulic powered attachments.
[Maximum pressure 4700 psi (32,400 kPa)
Maximum flow 30 GPM (114 L/min)]

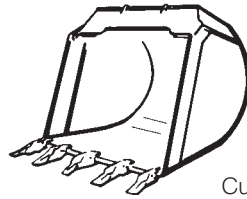

	Cu. yd.	m3
8045-6020 24" (610mm) Excavating bucket	3/8	.31
8045-6021 30" (762mm) Excavating bucket	1/2	.41
8045-6022 36" (914mm) Excavating bucket	5/8	.54
8045-6023 42" (1.07m) Excavating bucket	3/4	.64
8045-6024 48" (1.22m) Excavating bucket	1	.76

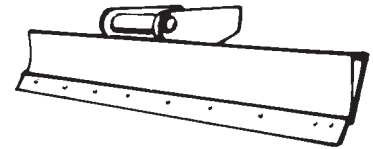

8065-6024 8' (2.4m) Grading blade

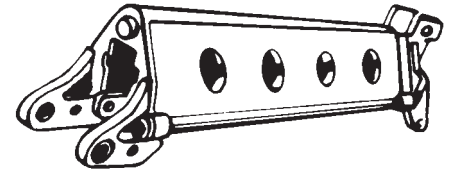

8045-5002 4' (1.2m) Boom extension
8045-5003 6' (1.8m) Boom extension
8045-5004 8' (2.4m) Boom extension
8045-5005 12' (3.7m) Tubular Boom extension

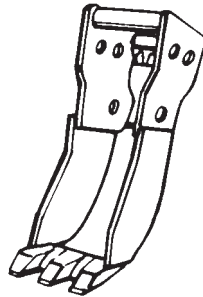

	Cu. yd.	m3
8065-6104 15" (381mm) Trenching bucket	1/5	.15
8065-6012 21" (533mm) Trenching bucket	1/4	.19

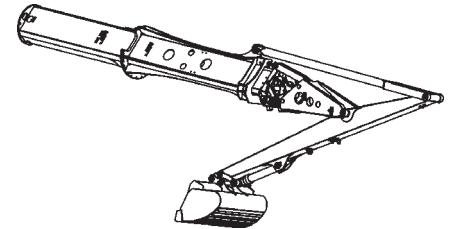

8045-5007 Telestick attachment

Attachments

Quick change and reversible buckets fabricated of steel plate, with high strength, low alloy cutting edges and wear strips. Standard attachments available for wide range of applications. Capacities shown are in heaped cu. yd.

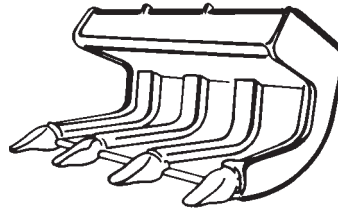

8065-6102 40" (1.02m) Pavement removal bucket

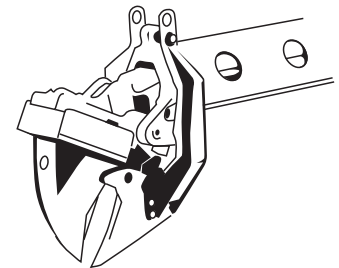

8045-5008 Tree Limb Shear Attachment

It is Gradall Policy to continually improve its products. Therefore designs, materials and specifications are subject to change without notice and without incurring any liability on units already sold. Units shown may have optional equipment.

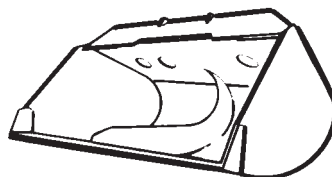

	Cu. yd.	m3
8065-6007 60" (1.52m) Ditching bucket	7/8	.73
8065-6006 66" (1.68m) Ditching bucket	1	.76
8065-6002 72" (1.83m) Ditching bucket	1 1/8	.87

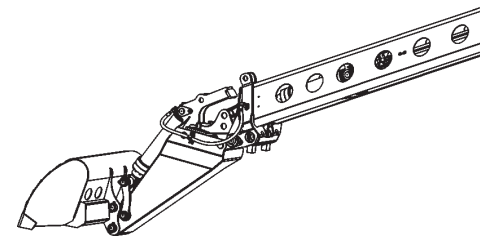

8045-5009 6' (1.8 m) Live Boom

GRADALL®

406 Mill Ave. SW, New Philadelphia, Ohio 44663
Phone: 330-339-2211 Fax: 330-339-8468
www.gradall.com



Certified ISO 9001

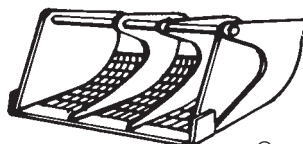

	Cu. yd.	m3
8065-6013 72" (1.83m) Dredging bucket	1 1/8	.87

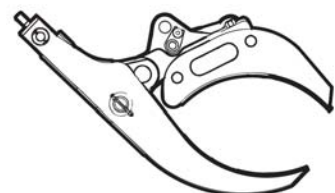

8045-5006 Fixed thumb grapple