

GRADALL®

XL 4300^{II} HYDRAULIC EXCAVATOR

SPECIFICATIONS



XL 4300^{II}

Upperstructure Engine

Deere 6068TF275 diesel, turbocharged, liquid cooled, 4 cycle, 6 cylinder, 414 cid (6.8 L) 4.19" bore x 5.00" stroke (106 mm x 127 mm) 170:1 compression ratio.

166 hp (124 kW) gross at 2,200 rpm, 146 hp (109 kW) net at 2,200 rpm. 429 ft-lb (582 Nm) gross torque at 1400 rpm.

Altitude capability: 10,000' (3,048 m). Derate 4% per 1,000' (305 m) above 10,000' (3,048 m).

Maximum slope: 45°

12 volt starter, 105 amp alternator, two SAE #C31-S 810 CCA batteries, two-stage dry type air cleaner with centrifugal precleaner and safety element. Evacuator valve and service indicator, spin-on oil filter, spin-on fuel filter/water separator.

Fuel tank capacity: 92 gallons (348 L).

Hydraulic System

PUMPS

One load-sensing, axial piston pump; oil flow 0-84 GPM (0-317 L/min).

One gear pump (brake and steering) 9.5 GPM (36 L/min).

SYSTEM MONITOR

Electronic monitor in cab indicates low hydraulic fluid level, high hydraulic fluid temperature, and condition of hydraulic suction and return filters.

SYSTEM SPECIFICATIONS

Eight cylinders

- 1 tool: 5.0" ID, 3.0" rod (127 mm x 76 mm), 22.5" (572 mm) stroke.
- 2 hoist: 4.25" ID, 3.15" rod (108 mm x 80 mm), 31.0" (787 mm) stroke.
- 1 telescope: 3.5" ID, 2.559" rod (89 mm x 65 mm), 12'6" (3.81 m) stroke.
- 2 stabilizers: 3.75" ID, 2.56" rod (95 mm x 65 mm), 24" (610 mm) stroke.
- 2 single-acting axle oscillation cylinders: 4.528" ID, 4.528" rod (115 mm x 115 mm), 6.25" (159 mm) stroke.

Three hydraulic motors

Swing, 51hp (38 kW); tilt, 18 hp (13 kW); propel motor, 113 hp (84 kW).

Operating pressures:

Hoist.....	4,900 psi	(33,784 kPa)
Tilt.....	2,200 psi	(15,168 kPa)
Swing.....	4,200 psi	(28,958 kPa)
Tool.....	4,900 psi	(33,784 kPa)
Telescope.....	4,900 psi	(33,784 kPa)
Propel.....	4,900 psi	(33,784 kPa)
Pilot System.....	500 psi	(3,448 kPa)
Braking and Steering.....	2,400 psi	(16,550 kPa)
Blade and Stabilizers.....	4,000 psi	(27,579 kPa)

Oil Capacity

Reservoir 48 gallons (182 L), system 68 gallons (257 L). Pressurized reservoir with visual oil level gauges.

Filtration System

10 micron return filter with magnet and 100 mesh suction strainer in reservoir.

Fin and tube-type oil cooler with thermal by-pass and relief valves.

Pressure-compensated, load-sensing valves with circuit reliefs in all circuits.

Operator Cab

All-weather cab with tinted safety glass windows, skylight, acoustical lining, four-way adjustable operator's seat, filtered fresh air heater and defroster. Front window slides to overhead storage. Rearview mirrors on right and left sides. Standard equipment on the XL 4300-II includes operator's seat belt, windshield wiper and washer, high/low beam headlights, parking lights, brake lights, 4-way hazard lights, turn indicator lights, and swing lights.

Controls

Two hydraulic joysticks (hoist & bucket, telescope & swing), one rocker switch (tilt) control upperstructure. Hydraulic joysticks mounted on arm pods, independently adjustable for individual operator comfort and convenience. Joysticks are self-centering; when controls are released, power for movement disengages and swing and tilt brake set automatically.

A tilting/telescoping steering column provides smoother, comfortable steering. Hydraulic foot pedal controls braking functions, giving smoother performance with infinite control. Travel speed is regulated with an electronic foot pedal control. A switch on the FWD/REV selector provides 1st/2nd gear selection. Independent rocker switches control stabilizers, axle oscillation, park brake, and hazard lights. Another switch on the column provides marker lights, high/low headlights, and direction indicators.

Engine Controls and Instrumentation

Key operated ignition/starter switch, throttle, hour meter and air cleaner condition indicator. Electronic monitor indicates fuel level, low battery charge, coolant level, hydraulic oil level, lube oil pressure, high coolant temperature, and engine rpm. Fuel saving auto idle feature sends engine rpm to idle when control circuits are in neutral for seven seconds.

Swing

Priority swing circuit with axial piston motor. Planetary transmission.

Swing speed: 8.0 rpm.

Swing Brake

Automatic spring-set/hydraulic release wet disc parking brake. Dynamic braking is provided by the hydraulic system.

Undercarriage

A full-time 4-wheel drive transfer case delivers power from the hydraulic drive motor to the drive axles. Both axles are equipped with internal wet-disc type service brakes. The steering axle is fitted with oscillation lock cylinders. Two stabilizer arms provide a solid digging platform for increased stability. A blade attachment for finish grading (as shown) is one of many options available for specific applications.

Tires: 10.00 x 20 Super-Lug

Axles: ZF Model 765-P4

Transmission: ZF Model 2HL 100

Drive Motor: Rexroth A6 Series, 160cc/Rev.

Minimum Turning Radius: 23'5" (7.16m)

Undercarriage Drive

Variable displacement high torque piston motor powers the 2-speed power shift transmission. Speed mode selection can also be done while moving. Electronically operated travel alarm signals excavator movement.

Travel speed on flat, level surface—mph (kmh/hr):

	Creeper Mode	Standard Mode
First Gear	1.3 mph (2.1 kmh)	4.2 mph (6.8 kmh)
Second Gear	5.0 mph (8.0 kmh)	16.5 mph (26.6 kmh)

Weight

Approximate working weight with 36" (914mm) excavating bucket, fuel tank half full, without blade 44,260 lb (20,076 kg), with optional blade 45,700 lb (20,729 kg). With optional front outriggers 46,600 lb (21,137 kg).

Rated bucket breakout force:

25,449 lb (113.2 kN).

Rated boom force: 22,075 lb (98.2 kN).

GRADALL Model XL 4300 Excavator Rated Lift Capacity Over End or Side on Tires, Axle Oscillation Cylinders Locked: LB (KG)

LOAD POINT HEIGHT		LOAD RADIUS					
		MIN. RADIUS	10' (3m)	15' (4.6m)	20' (6.1m)	25' (7.6m)	MAX. RADIUS
Above Ground Level	20' (6.1m)	5647 @ 21' 1" (2567 @ 6.4m)			6001 (2728)		5035 @ 23' 1" (2289 @ 7.0m)
	15' (4.6m)	12535 @ 12' 5" (5698 @ 3.8m)		10136 (4607)	7101 (3228)	5196 (2362)	5029 @ 25' 7" (2286 @ 7.8m)
	10' (3.0m)	13016 @ 14' 1" (5916 @ 4.3m)		11986 (5448)	7995 (3634)	5584 (2538)	4976 @ 26' 9" (2262 @ 8.2m)
	BOOM LEVEL 8'6" (2.4m)	12970 @ 14' 5" (5895 @ 4.4m)		12285 (5584)	7951 (3614)	5557 (2526)	4908 @ 26' 10" (2231 @ 8.2m)
	5' (1.5m)	12747 @ 14' 5" (5794 @ 4.4m)		12117 (5508)	7799 (3545)	5467 (2485)	4819 @ 26' 11" (2190 @ 8.2m)
At Ground Level		13034 @ 12' 9" (5925 @ 3.9m)		11146 (5066)	7580 (3445)	5337 (2426)	4957 @ 26' 2" (2253 @ 8.0m)
Below Ground Level	5' (1.5m)	8622 @ 7' 5" (3919 @ 2.3m)	10220 (4645)	8967 (4076)	6983 (3174)		5490 @ 24' 2" (2495 @ 7.4m)
	10' (3.0m)	6007 @ 8' 6" (2730 @ 2.6m)	6783 (3083)	6906 (3139)	5861 (2664)		5678 @ 20' 9" (2581 @ 6.3m)
		4499 @ 9' 10" (2045 @ 3.0m)	4557 (2071)				5247 @ 14' 9" (2385 @ 4.5m)
	15' (4.6m)						

NOTE: Shaded areas represent 75% of tipping capacity per SAE J1097 NOV88. All other values represent 87% of hydraulic lift capacity per SAE J1097 NOV88.

All loads are based on a standard machine equipped with 7500 lb (3409 kg) of counterweight, standard boom, 10.00-20 dual tires front and rear, pressure boost activated, no bucket, no aux. hydraulics.

Adjust the listed capacities according to each bucket as follows:

8065-6007 60" (1.5 m) ditching, subtract 807 lb (367 kg)
 8065-6101 48" (1219 mm) excavating, subtract 904 lb (411 kg)
 8065-6100 42" (1067 mm) excavating, subtract 792 lb (360 kg)
 8065-6099 36" (914 mm) excavating, subtract 707 lb (322 kg)
 8065-6102 40" (1016 mm) pavement removal, subtract 1262 lb (573 kg)

NOTE: Bucket adjustment values are 87% of the actual bucket weights. The load point is located on the bucket pivot point, including loads listed for maximum radius.

GRADALL Model XL 4300 Excavator Rated Lift Capacity Over End or Side on Tires & Outriggers, Axle Oscillation Cylinders Locked: LB (KG)

LOAD POINT HEIGHT		LOAD RADIUS					
		MIN. RADIUS	10' (3m)	15' (4.6m)	20' (6.1m)	25' (7.6m)	MAX. RADIUS
Above Ground Level	20' (6.1m)	5647 @ 21' 1" (2567 @ 6.4m)			6001 (2728)		5035 @ 23' 1" (2289 @ 7.0m)
	15' (4.6m)	12535 @ 12' 5" (5698 @ 3.8m)		10136 (4607)	7101 (3228)	5196 (2362)	5029 @ 25' 7" (2286 @ 7.8m)
	10' (3.0m)	13016 @ 14' 1" (5916 @ 4.3m)		11986 (5448)	7995 (3634)	5708 (2595)	5112 @ 26' 9" (2324 @ 8.2m)
	BOOM LEVEL 8'6" (2.4m)	12970 @ 14' 5" (5895 @ 4.4m)		12285 (5584)	8114 (3702)	5795 (2634)	5140 @ 26' 10" (2336 @ 8.2m)
	5' (1.5m)	13066 @ 14' 6" (5939 @ 4.4m)		12490 (5677)	8325 (3784)	5931 (2696)	5248 @ 26' 11" (2385 @ 8.2m)
At Ground Level		13034 @ 12' 9" (5925 @ 3.9m)		11146 (5066)	7918 (3599)	5797 (2635)	5415 @ 26' 2" (2461 @ 8.0m)
Below Ground Level	5' (1.5m)	8622 @ 7' 5" (3919 @ 2.3m)	10220 (4645)	8967 (4076)	6983 (3174)		5490 @ 24' 2" (2495 @ 7.4m)
	10' (3.0m)	6007 @ 8' 6" (2730 @ 2.6m)	6783 (3083)	6906 (3139)	5861 (2664)		5678 @ 20' 9" (2581 @ 6.3m)
		4499 @ 9' 10" (2045 @ 3.0m)	4557 (2071)				5247 @ 14' 9" (2385 @ 4.5m)
	15' (4.6m)						

Do not attempt to lift or hold any load greater than these rated values at specified load radii and heights. The weight of slings and any auxiliary lifting devices must be deducted from the rated load to determine the net load that may be lifted.

NOTE: All rated loads are based on the machine being stationary and level on a firm supporting surface. For safe working loads, the user must make due allowance for his particular job conditions, such as soft or uneven ground, out of level conditions, side loads, hazardous conditions, experience of personnel, etc. The operator and other personnel must fully acquaint themselves with the Operator's Manual furnished by the manufacturer before operating this machine, and rules for safe operation of equipment must be adhered to at all times.

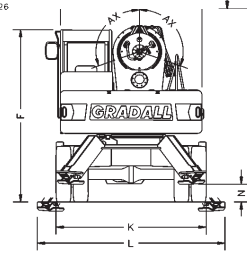
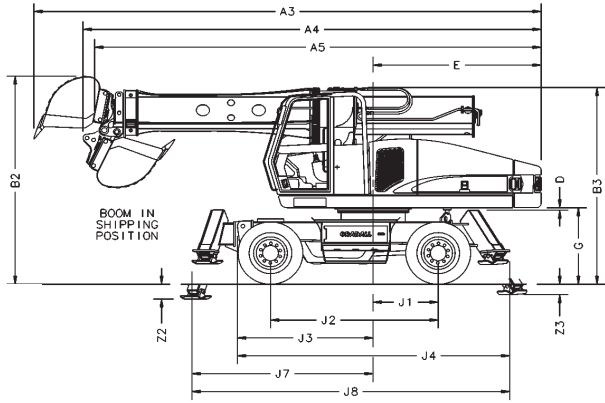
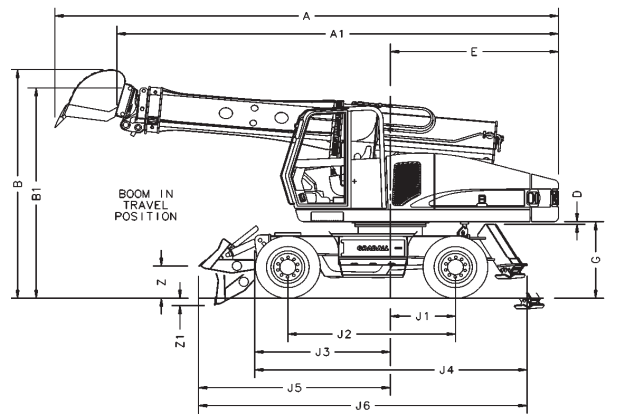
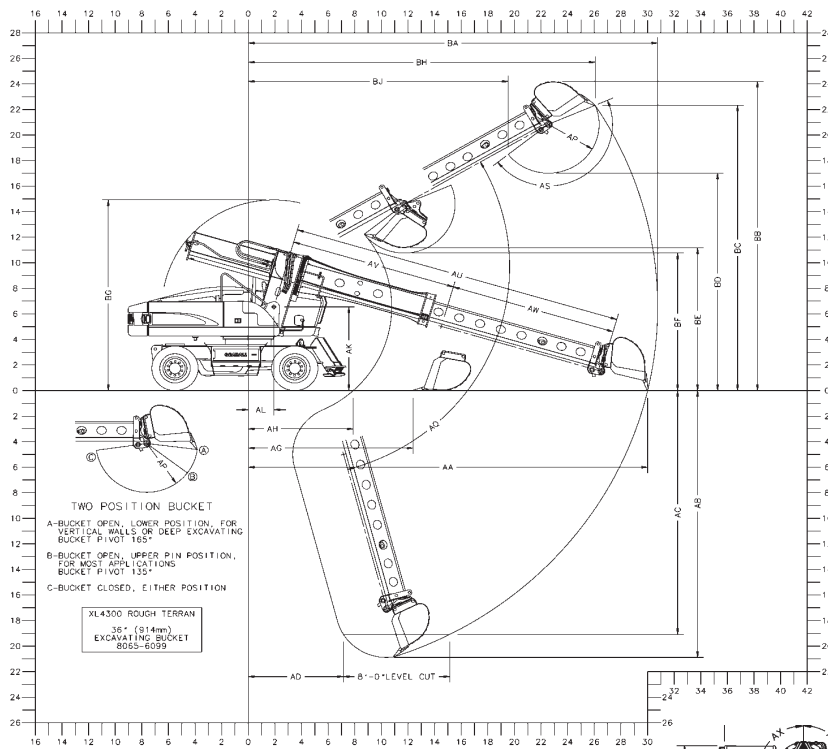

Dimensions

Shown with 8065-6099 36" (914mm) excavating bucket

- A** Overall length with bucket open (travel position): 27'0" (8.2)
- A1** Overall length without bucket (travel position): 23'8" (7.2)
- A3** Overall length with bucket open (shipment position): 27'3" (8.3)
- A4** Overall length with bucket closed (shipment position): 24'7" (7.5)
- A5** Overall length without bucket (shipment position): 24'0" (7.3)
- B** Overall height with bucket open (travel position): 12'10" (3.9)
- B1** Overall height without bucket (travel position): 11'9" (3.6)
- B2** Overall height with bucket open (shipment position): 11'8" (3.5)
- B3** Overall height without bucket (shipment position): 11'0" (3.3)
- C1** Width of upperstructure: 8'6" (2.6)
- D** Minimum clearance, upperstructure to undercarriage: 2" (51mm)
- E** Swing clearance, rear of upperstructure: 9'0" (2.7)
- F** Top of cab to groundline: 10'9" (3.3)
- G** Clearance, upperstructure to groundline: 4'3" (1.3)
- J1** Axis of rotation to centerline of fixed axle: 3'6" (1.1)
- J2** Wheelbase of undercarriage: 9'0" (2.7)
- J3** Axis of rotation to front of undercarriage: 7'3" (2.2)
- J4** Nominal overall length of undercarriage: 14'7" (4.4)
- J5** Axis of rotation to front of blade option (travel position): 10'4" (3.1)
- J6** Nominal overall length of undercarriage with blade option (travel position): 17'8" (5.4)
- J7** Axis of rotation to front of stabilizer option (travel position): 9'9" (3)
- J8** Nominal overall length of undercarriage with stabilizer option (travel position): 17'1" (5.2)
- K** Overall width (stabilizers up): 9'0" (2.7)
- L** Width across grounded stabilizers: 11'3" (3.4)
- N** Ground clearance (per SAE J1234): 13" (330 mm)
- Z** Blade above ground (option): 22" (559 mm)
- Z1** Maximum lift of stabilizers: 5" (127 mm)
- Z2** Maximum lift of stabilizers (option): 10" (254 mm)
- Z3** Maximum lift of rear stabilizers: 7" (178 mm)
- AA** Maximum radius at groundline (165° pivot): 30'0" (9.1)
- AB** Maximum digging depth (165° pivot): 20'11" (6.4)
- AC** Maximum depth for 8' level cut: 19'1" (5.8)

- AD** Minimum radius for 8' level cut at depth "AC": 7'2" (2.2)
- AG** Minimum level cut radius with bucket flat on groundline: 12'5" (3.8)
- AH** Minimum radius at groundline: 7'11" (2.4)
- AK** Boom pivot to groundline: 6'7" (2)
- AL** Boom pivot to axis of rotation: 23" (584 mm)
- AP** Bucket tooth radius: 46" (1168 mm)
- AQ** Boom pivot angle: 30° Up and 75° Down
- AS** Bucket pivot angle: 135° & 165°
- AU** Maximum telescoping boom length (boom pivot to bucket pivot): 25'0" (7.6)
- AV** Minimum telescoping boom length (boom pivot to bucket pivot): 12'6" (3.8)
- AW** Telescoping boom travel: 12'6" (3.8)
- AX** Bucket tilt angle (both sides of center): 110°
- BA** Maximum radius of working equipment (165° pivot): 30'9" (9.4)
- BB** Maximum height of working equipment: 24'2" (7.4)
- BC** Maximum bucket tooth height: 22'4" (6.8)
- BD** Minimum clearance of bucket teeth with bucket pivot at maximum height: 17'0" (5.2)
- BE** Minimum clearance of fully curled bucket at maximum boom height (165° pivot): 11'2" (3.4)
- BF** Minimum clearance of bucket teeth at maximum boom height: 10'9" (3.3)
- BG** Maximum height of working equipment with bucket below groundline: 14'11" (4.5)
- BH** Radius of bucket teeth at maximum height (165° pivot): 26'1" (7.9)
- BJ** Minimum radius of bucket teeth at maximum bucket pivot height (165° pivot): 19'6" (5.9)

Transport dimensions without attachment:

- Length: 23'8" (7.2)
- Height: 11'9" (3.6)
- Width: 9'0" (2.7)

Metric units are meters (m) unless noted

Optional Equipment

Work lights: 2 spotlights on boom cradle, 3 floodlights on cab, 1 floodlight on right front shrouding.

Vandalism protection kit including window covers.

Intake air pre-cleaner.

Exhaust spark arrestor.

Strobe light.

Block heater.

Additional battery.

Air conditioning.

AM/FM radio installation.

Auxiliary Hydraulics - Inside hose trough with additional hosing and piping for hydraulic powered attachments.
[Maximum pressure 4700 psi (32,400 kPa)
Maximum flow 30 GPM (114 L/min)]

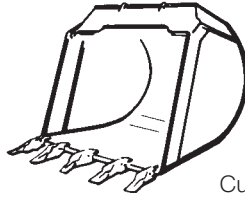

8045-6020	24" (610mm)	Excavating bucket	Cu. yd.	m3
			3/8	.31
8045-6021	30" (762mm)	Excavating bucket	1/2	.41
8045-6022	36" (914mm)	Excavating bucket	5/8	.54
8045-6023	42" (1.07m)	Excavating bucket	3/4	.64
8045-6024	48" (1.22m)	Excavating bucket	1	.76

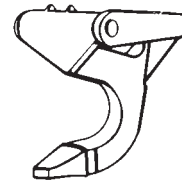

8065-6009 Single-tooth ripper

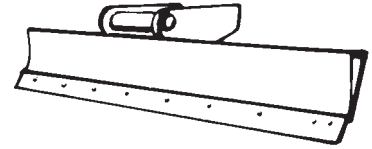

8065-6024 8' (2.4m) Grading blade

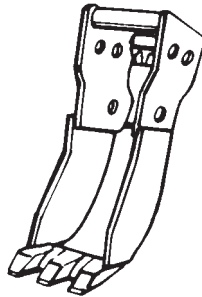

8065-6104	15" (381mm)	Trenching bucket	Cu. yd.	m3
			1/5	.15
8065-6012	21" (533mm)	Trenching bucket	1/4	.19

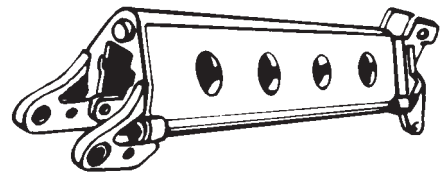

8045-5002	4' (1.2m)	Boom extension
8045-5003	6' (1.8m)	Boom extension
8045-5004	8' (2.4m)	Boom extension
8045-5005	12' (3.7m)	Tubular Boom extension
8045-5007		Telestick attachment

Attachments

Quick change and reversible buckets fabricated of steel plate, with high strength, low alloy cutting edges and wear strips. Standard attachments available for wide range of applications. Capacities shown are in heaped cu. yd.

It is Gradall Policy to continually improve its products. Therefore designs, materials and specifications are subject to change without notice and without incurring any liability on units already sold. Units shown may have optional equipment.

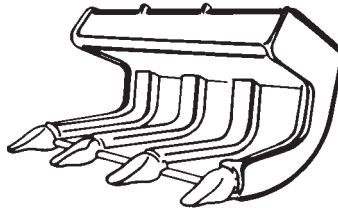

8065-6102 40" (1.02m) Pavement removal bucket

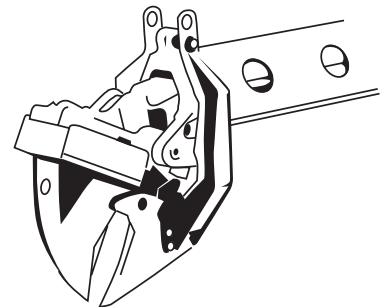

8045-5008 Tree Limb Shear Attachment

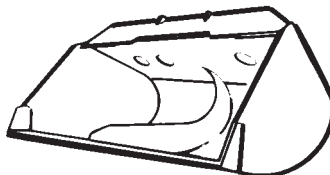

8065-6007	60" (1.52m)	Ditching bucket	Cu. yd.	m3
			7/8	.73
8065-6006	66" (1.68m)	Ditching bucket	1	.76
8065-6002	72" (1.83m)	Ditching bucket	1 1/8	.87

ATTACHMENTS

Buckets fabricated of steel plate, with high strength, low alloy cutting edges and wear strips. Standard attachments available for wide range of applications. Capacities shown are in heaped cu. yd.

GRADALL®

406 Mill Ave. SW, New Philadelphia, Ohio 44663
Phone: 330-339-2211 Fax: 330-339-8468
www.gradall.com



Certified ISO 9001

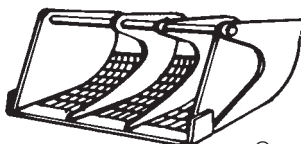

8065-6013	72" (1.83m)	Dredging bucket	Cu. yd.	m3
			1 1/8	.87