

GRADALL®

XL 5110

INDUSTRIAL MAINTENANCE MACHINE

SPECIFICATIONS



XL 5110

Upperstructure Engine

Mercedes OM-906 Diesel MSHA Certified
201 HP at 2200 RPM. 553 ft. lb. torque at
1200 RPM. 6 cylinder, inlin 6.37 L
Displacement (389 cu-in.). Turbocharged.
Air to air aftercooled.

Maximum slope: 45°

12 volt starter, 130 amp alternator, two SAE
#C31S 1000 CCA batteries, (2) two-stage
dry-type air cleaner with centrifugal precleaner,
ejector valve and service indicator.
Fuel tank capacity: 95 gallons (379L)

Hydraulic System

PUMPS

Power Steering-Axial Piston 0-25 GPM

Main Two Load sensing axial piston
pumps; 0-55 GPM (0-208 L/min)
each.

Swing Axial piston pump; 0-16 GPM
(0-61 L/min).

Auxiliary Tandem gear pump for hydraulic
brakes, pilot control, and cooling
circuits 20.6 GPM (78 L/min).

SYSTEM MONITOR

Monitor in cab indicates low hydraulic fluid
level, high hydraulic fluid temperature, and
condition of return and suction filters.

SYSTEM SPECIFICATIONS

Four double-acting cylinders

- 2 boom hoist: 6" ID, 3.25" rod
(152mm x 83mm) 55.5" (1410mm) stroke.
- 1 tool: 6" ID, 3.25" rod (127mm x 83mm),
18.75" (476mm) stroke.
- 1 telescope: 5" ID, 3.25" rod
(127mm x 83mm), 13'6" (3.94m) stroke.

Hydraulic motors

Swing, 28 hp (21kW); tilt, 28 hp (21kW); two
remote drive, 140 hp (104kW).

Operating pressures

Hoist	2400 psi (16,536 kPa)
Tilt	3000 psi (20,670 kPa)
Swing	3000 psi (20,670 kPa)
Tool	2000 psi (13,780 kPa)
Telescope	1750 psi (12,058 kPa)
Remote Propel	4700 psi (32,383 kPa)
Pilot system	480 psi (3,307 kPa)

Auxiliary hydraulic oil cooler

Oil capacity

Reservoir 75 gallons (284L), system 100
gallons (379L). Pressurized reservoir with
visual oil level gauges.

Filtration system

Combination of eight- and ten-micron in-line
suction and return filters, plus ten-micron
return filter and 100 mesh strainer in reservoir.

Fin- and tube-type oil cooler, with thermal
bypass and relief valves.

Pressure compensated load-sensing valves
with circuit reliefs in all valves.

Cab

Cab with safety glass windows, (2) windshield
wipers, acoustical lining, four-way adjustable
operator's seat, work lights, fire extinguisher,
filtered fresh air heater and defroster.

Controls

Two hydraulic joysticks (hoist & bucket,
telescope & swing) and one rocker switch
(tilt) control upperstructure. Hydraulic joysticks
mounted on armrests are independently
adjustable for individual operator comfort and
convenience.

Two foot pedals for hydraulic remote control
of undercarriage, travel and brakes. Electric
switch selects low range or high range.

Joysticks and pedals are self-centering; when
controls are released power for movement
disengages and swing and travel brakes set
automatically (in low range only). Tilt steering
wheel controls rear axle steering.

Engine controls

Key-operated ignition/starter switch, throttle,
hour meter and air cleaner condition
indicator. Electronic monitor indicates fuel
level, low battery charge, coolant level and
lube oil pressure, high coolant temperature,
and engine rpm.

Gauges For: Tachometer, oil pressure,
coolant temperature, fuel level, hydraulic oil
temperature and voltmeter.

Indicator Lights For: Check engine and
engine stop.

Swing

Independent closed loop swing circuit with
axial piston pump and motor. Planetary
transmission.

Swing speed: 0-3.1 rpm.

Swing brake

Automatic swing parking brake, spring-set
hydraulic release. Dynamic braking provided
by hydraulic system.

Undercarriage

4 x 2; rear-wheel steer, front wheel-drive.

Steer axle: Oscillating axle assembly with
Meritor wheel ends.

Air spring suspension.

Twin steering cylinders.

Drive axle: Variable displacement piston motor
and planetary reduction power each drive
wheel, air spring suspension.

Oscillating axle assembly with Meritor
wheel ends.

Brakes: Four-wheel service and working
air brakes.

Frame: Welded box frame with W18 at 65 lb
per ft. A-36 steel beams with T-1 steel top and
bottom reinforcement plates. Access ladder
and service platform both sides.

Tires: 16.00 x 25 (24 PLY) ND LCM E-3.

Travel speed: 6 mph.

Gradeability: 35%

Weight

Approximate working weight - 62,000 lb
(28,123kg).

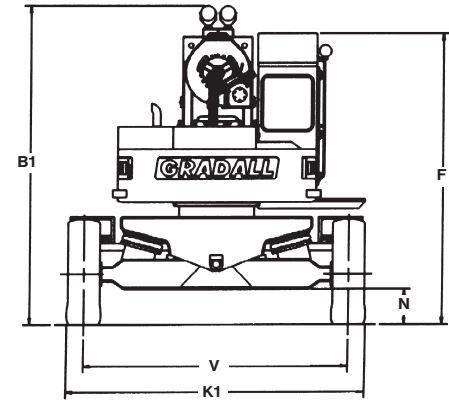
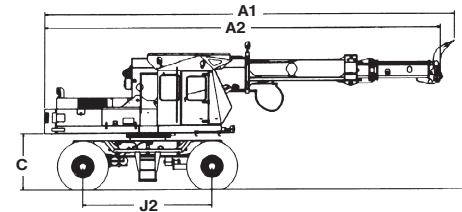
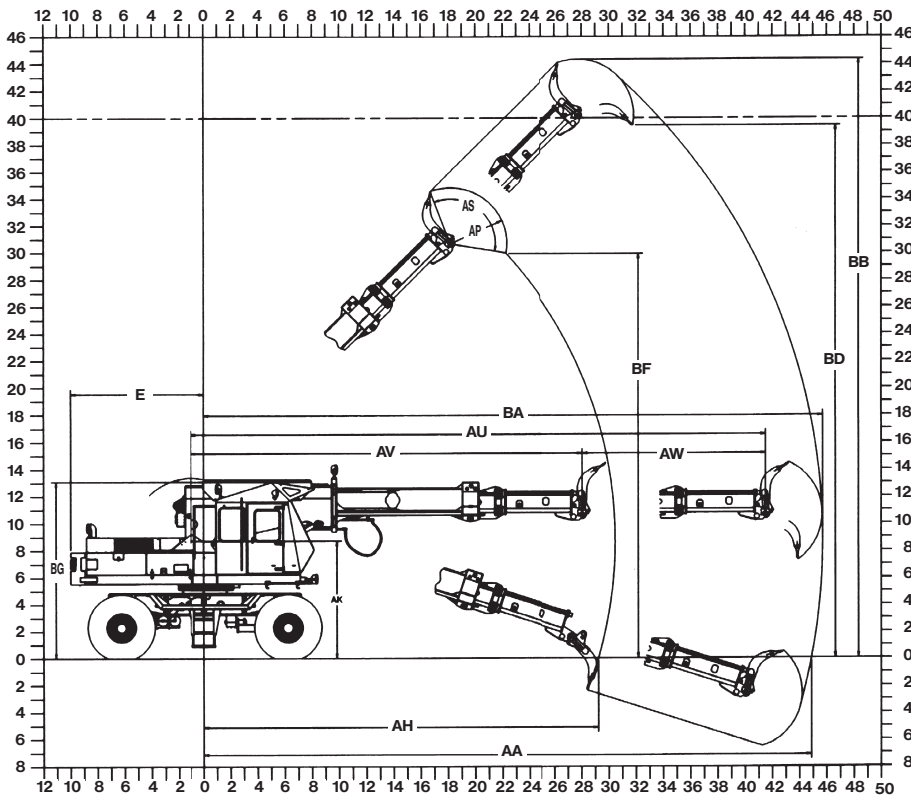

(Meters shown in parentheses)

- A1** Overall length (boom level) with scaling hook: 39' 9" (12.1)
- A2** Overall length (boom level) without scaling hook: 38' 5" (11.7)
- B1** Overall height (boom level): 14' 4" (4.4)
- E** Swing clearance, rear of upperstructure: 10' 0" (3.0)
- F** Top of cab to groundline: 13' 1" (4.0)
- G** Clearance, upperstructure to groundline: 5' 6" (1.7)
- J2** Nominal distance between centerlines of drive and steer axles: 12' 6" (3.8)
- K1** Width of chassis: 13' 7" (4.1)
- N** Ground clearance: 1' 7" (0.5)
- V** Wheel centerline to wheel centerline: 12' 0" (3.7)
- AA** Maximum radius at groundline: 44' 11" (13.7)
- AB** Maximum depth: 6' 6" (2.0)
- AH** Minimum radius at groundline: 29' 3" (8.9)
- AK** Boom pivot to groundline: 8' 9" (2.7)
- AP** Scaling hook tooth radius: 4' 2" (1.3)
- AS** Attachment pivot angle: 120°
- AU** Maximum telescoping boom length (boom pivot to attachment pivot): 42' 6" (13.0)
- AV** Minimum telescoping boom length (boom pivot to attachment pivot): 29' 0" (8.8)
- AW** Telescoping boom travel: 13' 6" (4.1)

- AX** Standard boom tilt angle: 270°
- BA** Maximum radius of working equipment: 45' 8" (13.9)
- BB** Maximum height of working equipment: 44' 4" (13.5)
- BD** Minimum clearance of scaling tooth, with attachment pivot at maximum height: 39' 5" (12.0)
- BE** Minimum clearance of scaling tooth at maximum boom height: 29' 11" (9.1)
- BG** Maximum height of working equipment with boom below groundline: 13' 1" (4.0)

It is Gradall Policy to continually improve its products. Therefore, designs, materials and specifications are subject to change without notice and without incurring any liability on units already sold. Units shown may have optional equipment.

GRADALL®

406 Mill Ave. SW, New Philadelphia, Ohio 44663
 Phone (330) 339-2211 FAX (330) 339-8468
www.gradall.com